

Baulänge: EN 558-1 Reihe 20 (DIN 3202-K1) Face to face dimension: EN 558-1 line 20 (DIN 3202-K1)

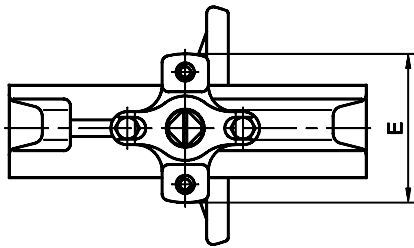
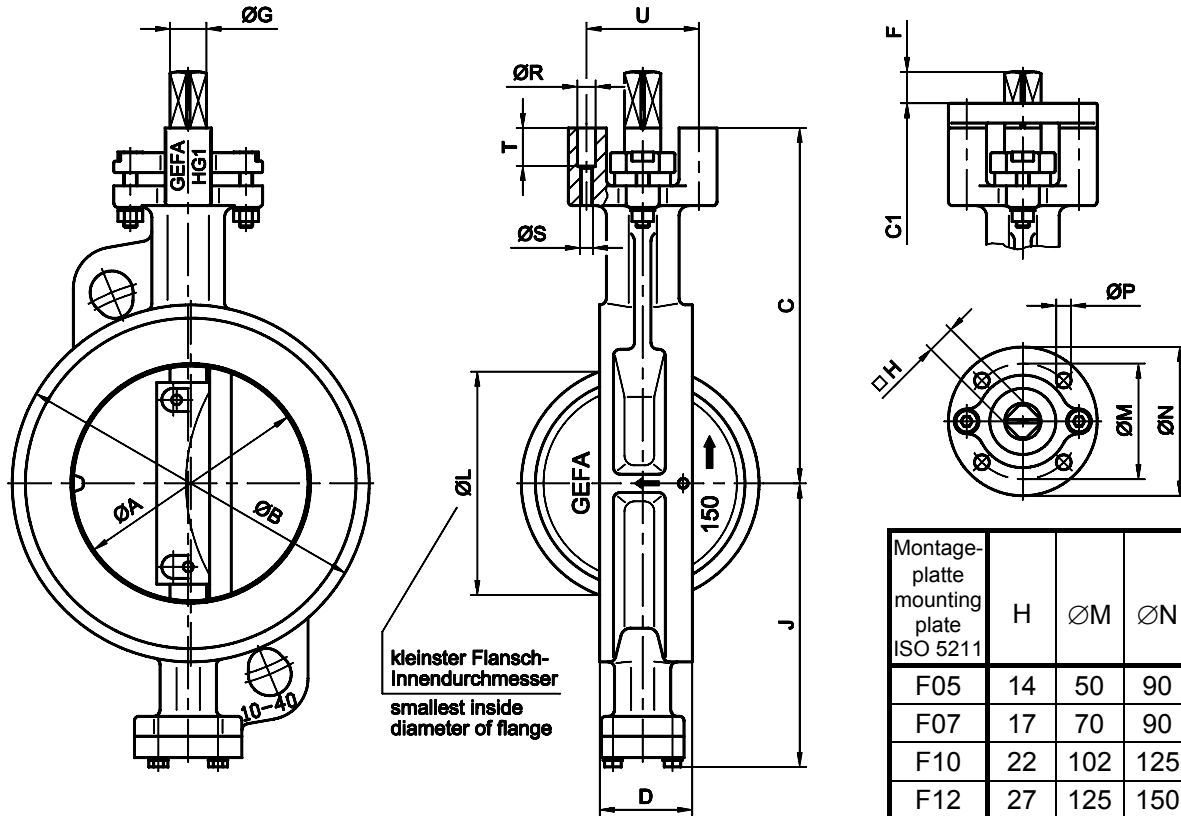

Montageplatte mounting plate ISO 5211	H	ØM	ØN	nxØP
F05	14	50	90	4x6,6
F07	17	70	90	4x9
F10	22	102	125	4x11
F12	27	125	150	4x14
F14	36	140	175	4x18
F16	46	165	210	4x22
F25	55	254	300	8x18

MULTITOP Montageplatte und Vierkant - Adapter zum Direktaufbau von Antrieben mit größerem Anschlußflansch. Sonderaufbauten möglich.

MULTITOP mounting plate and square - adapter for direct mounting of actuators with larger connection flange. Special designs possible.

DN	NPS	ØA	ØB	C	C1	D	E	F	G	J	ØL	ØR	ØS	T	U	kg	kleinster Anschluß min. mounting plate DIN 3337/ISO 5211
50	2"	47	102	142	157	43	90	16	18	103	46	11	M8	23	68	3,9	F05
65	2 1/2"	64	122	154	169	46	90	16	18	115	59	11	M8	23	68	4,7	F05
80	3"	76	133	162	177	46	90	16	18	122	76	11	M8	23	68	5,2	F05
100	4"	98	156	179	194	52	90	16	18	135	93	11	M8	23	68	6,7	F05
125	5"	119	188	197	212	56	90	19	22	152	118	11	M8	23	68	9,6	F07
150	6"	140	216	215	230	56	90	19	22	174	139	11	M8	23	68	11,7	F07
200	8"	190	268	262	280	60	125	24	28	216	190	13	M10	23	95	19,6	F10
250	10"	237	323	292	310	68	125	24	28	248	238	13	M10	23	95	28,0	F10
300	12"	280	375	336	356	78	150	29	36	283	281	16	M12	22	115	40,0	F12

Gewicht ohne Montageplatte
 Weight without mounting plate

Änderungen vorbehalten
 subject to changes